

NO.	REVISION	DATE	BY
1	ADDED BRAKE CONNECTOR TO PCB - SEPARATE WIRING	25JAN21	WJR

SAFE AND SECURE  
2000 ACTUATOR

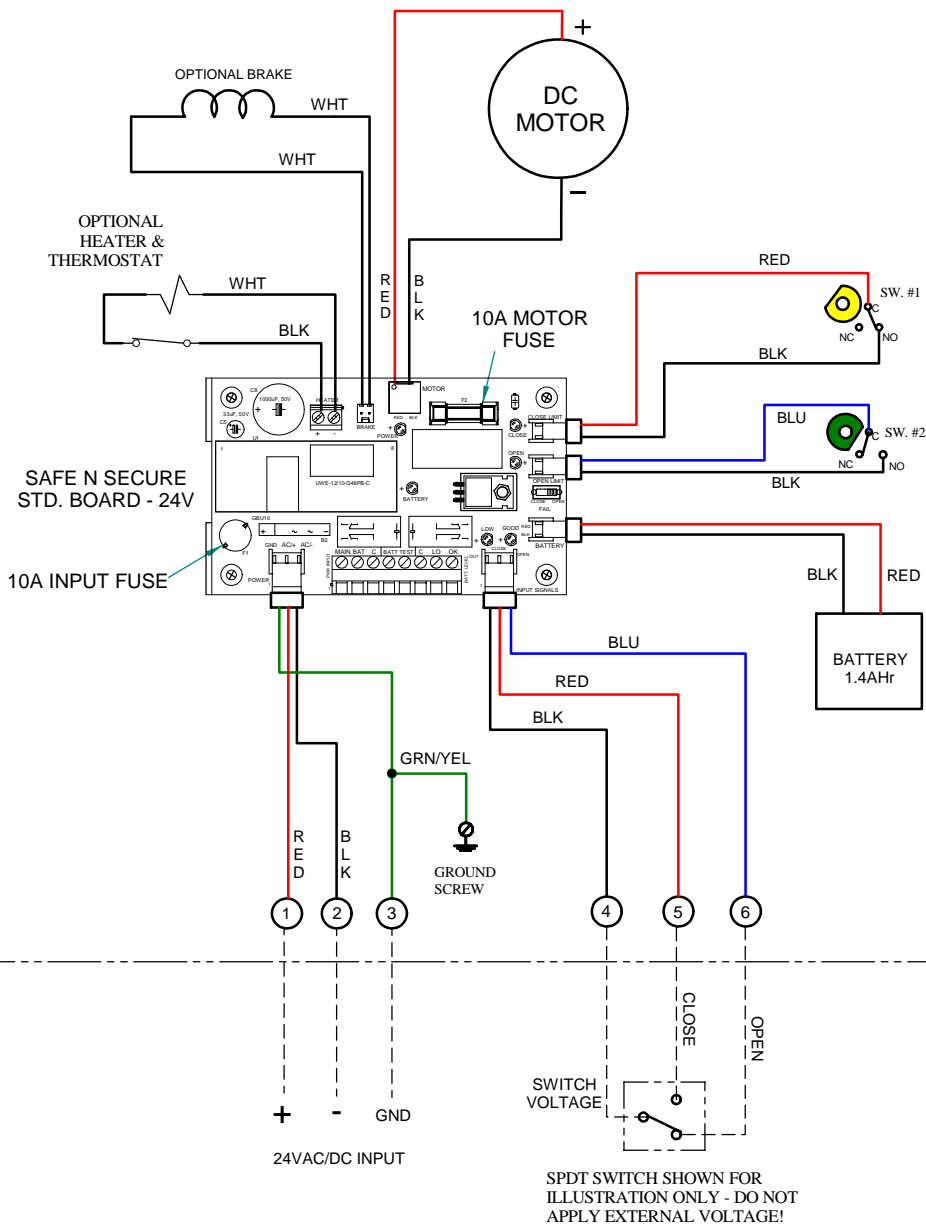

FIELD WIRING

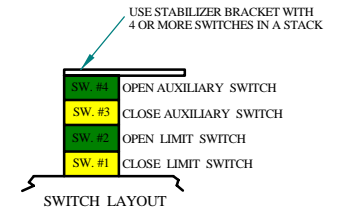

ACTUATOR SHOWN IN OPEN POSITION

NOTES:

- 1) INPUT POWER SOURCE TO BE 24VAC OR 24VDC @ 9.0A MINIMUM.
- 2) FUSE ON SNS BOARD IS SLOW BLOW, TR5 PLUG IN 10.0A, 250V.
- 3) UNIT IS SHIPPED WITHOUT THE BATTERY PLUGGED IN. AFTER INSTALLING UNIT AND CONNECTING INCOMING POWER, PLUG THE 2 PIN BATTERY CONNECTOR INTO THE 2 PIN HEADER ON THE BOARD (J2).
- 4) CAMS FOR LIMIT SWITCHES ARE PRESET AT THE FACTORY. TO INCREASE OR DECREASE VALVE MOTION, SLIGHTLY ADJUST THE OPEN AND CLOSE CAMS.
- 5) THE "FAIL" CONDITION IS SET PER THE SLIDE SWITCH ON THE SNS BOARD FOR FAIL OPEN OR FAIL CLOSE. USER IS TO SET THE "FAIL" POSITION SWITCH PRIOR TO APPLYING POWER TO THE UNIT.
- 6) WHEN INCOMING POWER IS PRESENT, BLUE LED WILL BE LIT AND ACTUATOR RUNS OFF OF INCOMING POWER. WHEN INCOMING POWER FAILS, BLUE LED WILL TURN OFF AND THE YELLOW BATTERY LED WILL LIGHT - ACTUATOR WILL MOVE TO THE "FAIL" POSITION 1 TIME AND STAY THERE UNTIL POWER IS RESTORED.
- 7) RED LED WILL LIGHT WHEN BATTERY VOLTAGE GETS TOO LOW. GREEN LED WILL LIGHT WHEN BATTERY VOLTAGE IS ABOVE 10.5VDC.
- 8) RED CONTACTS ARE PROVIDED TO INDICATE BATTERY STATUS AND INCOMING POWER STATUS. BATTERY STATUS CAN BE CHECKED WITH THE INCOMING POWER ON BY SHORTING THE 2 BATT TEST POINTS J7-2 & J10-1 MOMENTARILY.
- 9) CONTROL SIGNAL IS TO BE A DRY CONTACT SWITCH OR RELAY CONTACT ONLY! DO NOT APPLY VOLTAGE TO TERMINALS #4, #5 & #6!

