

NO.	REVISION	DATE	BY

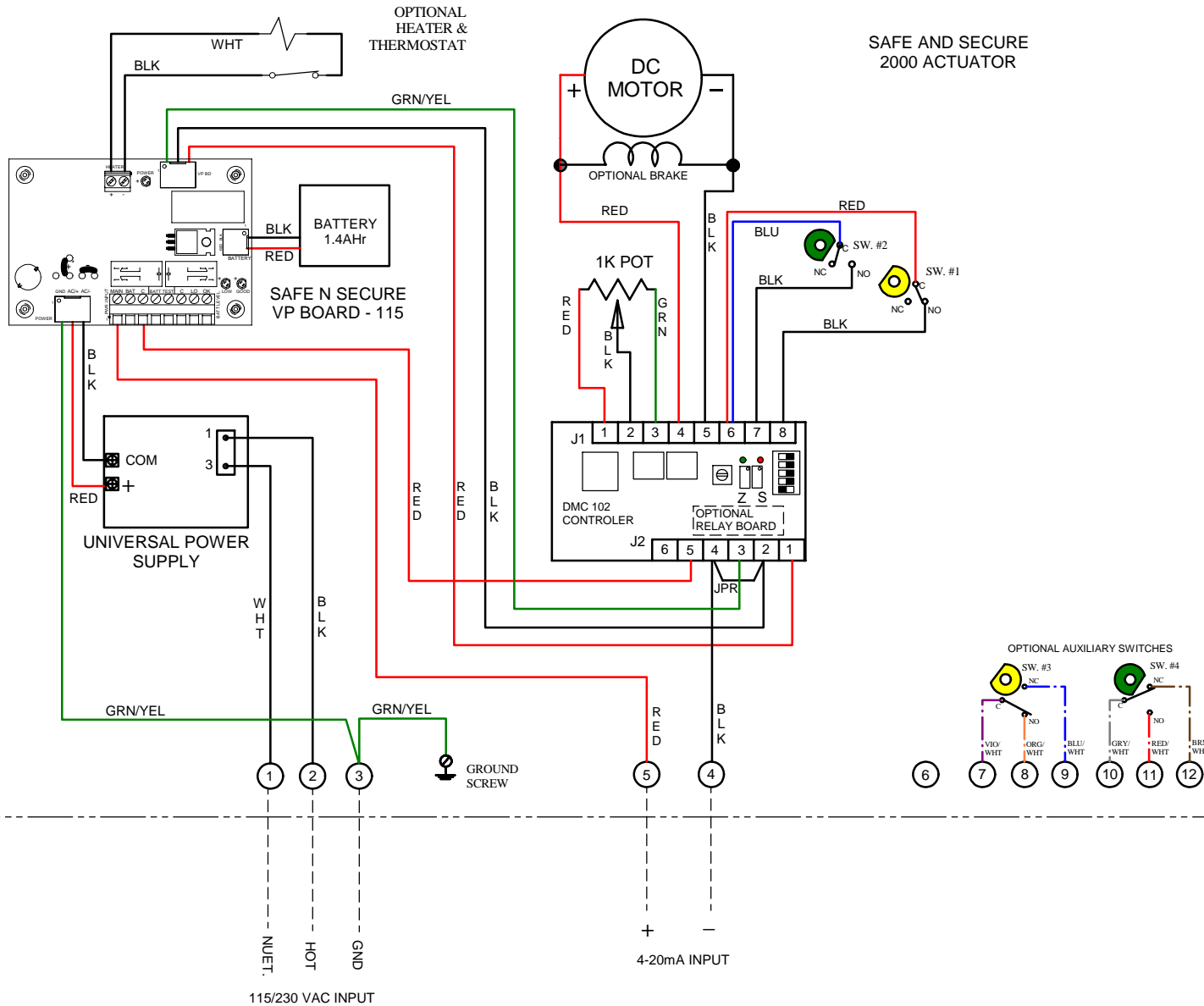

FIELD WIRING

SAFE AND SECURE
2000 ACTUATOR

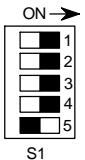
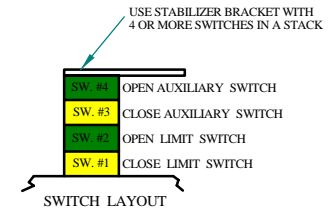

ACTUATOR SHOWN IN OPEN POSITION

NOTES:

- 1) INPUT POWER SOURCE TO BE 115VAC OR 230VAC. @ 1.2A MINIMUM.
- 2) INPUT FUSE IS PICO, TR5 AT 10A. 250VAC.
- 3) UNIT IS SHIPPED WITHOUT THE BATTERY PLUGGED IN. AFTER INSTALLING UNIT AND CONNECTING INCOMING POWER, PLUG THE POSITIVE BATTERY WIRE PUSH ON ONTO THE RED BATTERY TERMINAL.
- 4) CAMS FOR LIMIT SWITCHES ARE PRESET AT THE FACTORY. TO INCREASE OR DECREASE VALVE MOTION, ADJUST SLIGHTLY THE ZERO (Z) OR SPAN (S) POTS ON THE POSITIONER BOARD.
- 5) THE "FAIL" CONDITION IS SET PER THE DIP SWITCHES ON THE DMC-102 CONTROLLER BOARD - SEE DATA SHEET FOR SETTINGS FOR FAIL OPEN, CLOSE OR FAIL IN PLACE.
- 6) WHEN INCOMING POWER IS PRESENT, BLUE LED WILL BE LIT AND ACTUATOR RUNS OFF OF INCOMING POWER. WHEN INCOMING POWER FAILS, BLUE LED WILL TURN OFF AND THE YELLOW BATTERY LED WILL LIGHT - ACTUATOR WILL MOVE TO THE "FAIL" POSITION 1 TIME AND STAY THERE UNTIL POWER IS RESTORED.
- 7) RED LED WILL LIGHT WHEN BATTERY VOLTAGE GETS TOO LOW. GREEN LED WILL LIGHT WHEN BATTERY VOLTAGE IS ABOVE 10.5VDC.
- 8) 4-20mA SIGNAL IS DELIVERED TO THE DMC-102 DC BOARD TO OPEN AND CLOSE THE ACTUATOR.
- 9) DRY CONTACTS ARE PROVIDED TO INDICATE BATTERY STATUS AND INCOMING POWER STATUS. BATTERY STATUS CAN BE CHECKED WITH THE INCOMING POWER ON BY SHORTING THE 2 BATT TEST POINTS J7-2 & J10-1 MOMENTARILY.

